



MODEL : TRP100-III

Receipt Printer User's Manual

All specifications are subject to change without notice

A software tool is available to configure the printer settings on AURES technical website: www.ares-support.fr



Disposal of Old Electrical&Electronic Equipment(Applicable in the European Union and other European countries with separate collection systems)

This symbol on the product or on its packaging indicates that this product shall not be treated as household waste. Instead it shall be handed over to the applicable collection point for the recycling of electrical and electronics equipment. For more detailed information about recycling of this product, please contact your local city office, your household waste disposal service or the shop where you purchased the product.

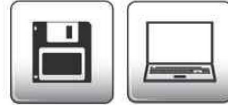

FR

Le Groupe AURES vous remercie de votre confiance.

Téléchargez nos derniers drivers et utilitaires ainsi que nos conseils d'installation sur le site du Support Technique AURES :

www.ares-support.fr

UK

The AURES Group thanks you for your loyalty.

To download our most recent drivers and utilities- and obtain advice regarding the installation of your equipment, please visit the AURES Technical Support Website:

www.ares-support.fr/UK

DE

Die AURES Gruppe bedankt sich für Ihre Bestellung.

Um unserneuesten Treiber, Utilities und Konfigurationsratschläge zu Ihren Produkten herunterzuladen besuchen Sie bitte unsere technische Support- Website:

www.ares-support.fr/GE

Table of Contents

| | |
|--------------------------------------|----|
| 1. Parts Identifications | 3 |
| 2. Setting up the printer | 4 |
| 2.1 Unpacking | 4 |
| 2.2 Connecting the cables | 5 |
| 2.3 Loading the roll paper | 9 |
| 2.4 Adjustment of paper width | 12 |
| 3. Control panel and other functions | 13 |
| 3.1 Control panel | 13 |
| 3.2 Error Indicating | 13 |
| 4. Self Test | 14 |
| 5. Hexadecimal Dump | 15 |
| 6. Printer cleaning | 16 |
| 7. Specifications | 17 |
| 7.1. General Specifications | 17 |
| 7.2. Auto Cutter Specifications | 19 |
| 7.3. Interface | 19 |
| 7.4. Electrical Characteristics | 19 |
| 7.5. Environmental Requirements | 20 |
| 7.6. Reliability | 20 |
| 7.7. Certification | 20 |
| 8. Command List | 21 |

1. Parts Identifications

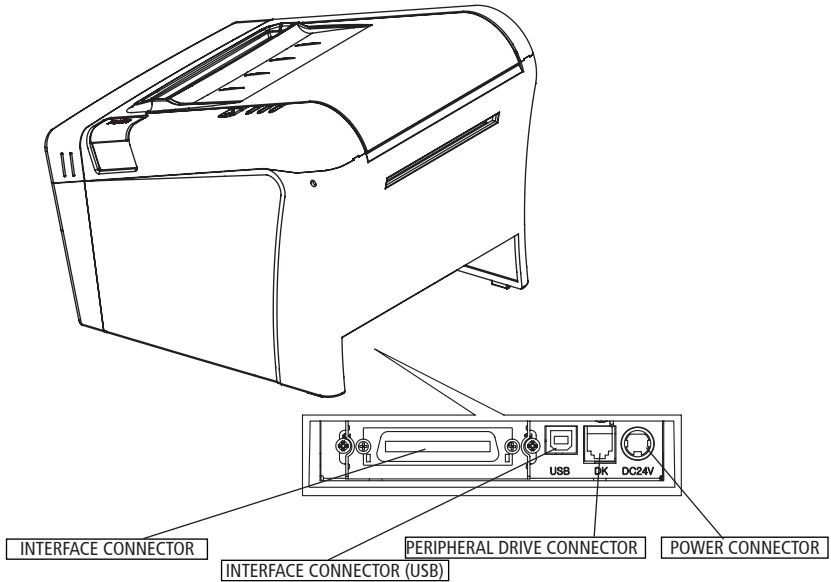
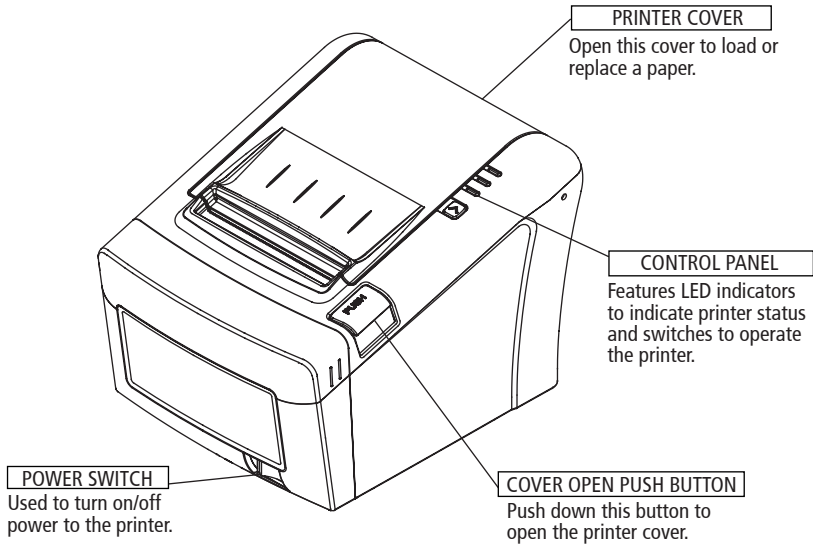

2. Setting Up the Printer

2-1. Unpacking

Your printer box should include these items. If any items are damaged or missing, please contact your dealer for assistance.

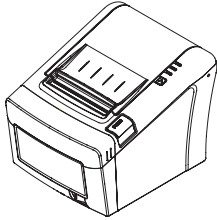

The Printer

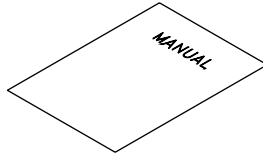

User's Manual

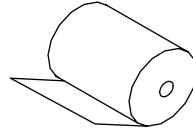

Roll Paper

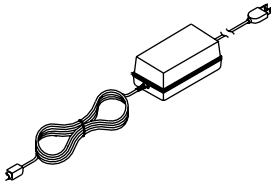

Adaptor(Optional)



Interface Cable(optional)

2-2. Connecting the Cables

All cables connect to the connector panel on the back of the printer which is shown below:

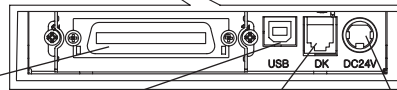
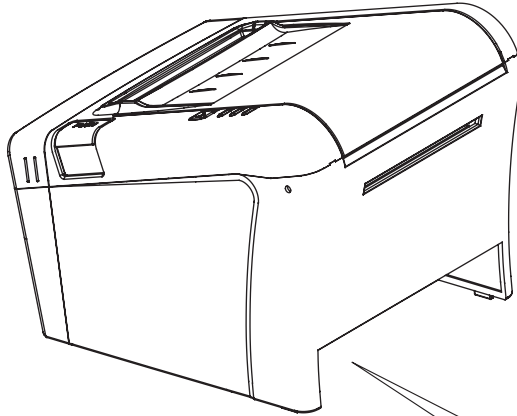

INTERFACE CONNECTOR

For connection to a host computer.

INTERFACE CONNECTOR (USB)

For connection to a host computer.

PERIPHERAL DRIVE CONNECTOR

Connects to peripheral units such as cash drawer, etc.
Do not connect this to a telephone.

POWER CONNECTOR

For connection of the AC adapter.
Never unplug the AC adapter while the printer is on.

Before connecting any of the cables, make sure that both the printer and the computer are turned off.

2-2-1. Interface Connector

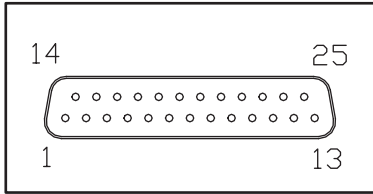

<D-SUB 25 Female Serial>

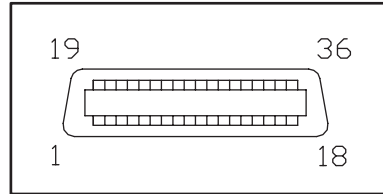

<Centronics Parallel>

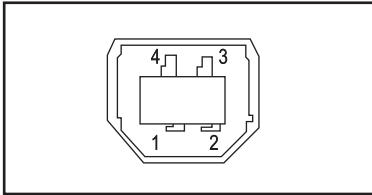

<USB "B" Type>

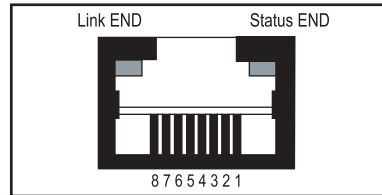

<Ethernet>

USB Interface

| Pin | Signal | I/O | Description |
|-----|--------|-----|----------------------------|
| 1 | +5V | - | +5V |
| 2 | DATA- | - | Printer transmit data line |
| 3 | DATA+ | - | Printer transmit data line |
| 4 | GND | - | System Ground |

Serial Interface

| PIN | SIGNAL | I/O | DESCRIPTION |
|-------|--------|--------|--|
| 2 | TxD | Output | Printer transmit data line RS-232C level |
| 3 | RxD | Input | Printer receive data line RS-232C level |
| 4, 20 | DTR | Output | Printer handshake to host line RS-232C level |
| 6 | DSR | Input | Data Send Ready |
| 1, 7 | GND | - | System Ground |

Centronics Parallel Interface

| PIN | SIGNAL | I/O | DESCRIPTION |
|-------|-------------|--------------|--|
| 1 | STROBE- | Input | Synchronize signal Data received |
| 2~9 | DATA0~7 | Input/Output | Data bit Transmitted 0~7 |
| 10 | ACK- | Output | Data receiving completed. |
| 11 | BUSY | Output | Impossible to print of data receiving. |
| 12 | PE | Output | Paper empty |
| 13 | SELECT | Output | Printer status for ON/OFF line |
| 14 | AUTO FEED- | Input | Paper auto feed signal |
| 15 | GROUND | - | System ground |
| 16 | GROUND | - | System ground |
| 17 | NC | - | |
| 18 | LOGIC-H | - | +5V |
| 19~30 | GROUND | - | System ground |
| 31 | INIT- | Input | Initialize |
| 32 | ERROR- | Output | Printer error |
| 33 | GROUND | - | System ground |
| 34 | NC | - | |
| 35 | +5V | - | +5V |
| 36 | SELLECT IN- | Input | Printer select signal |

Ethernet Interface

| PIN | SIGNAL | I/O |
|-----|------------|---------------|
| 1 | Data Out + | Output Data + |
| 2 | Data Out - | Output Data - |
| 3 | GND | Ground |
| 4 | Data IN + | Input Data + |
| 5 | Data IN - | Input Data - |
| 6 | N.C | |
| 7 | N.C | |
| 8 | N.C | |

2-2-2. Cash Drawer Connector

The printer can operate two cash drawers with a 6 pin RJ-11 modular connector.

The driver is capable of supplying a maximum current of 0.1A for 510ms or less when not printing.

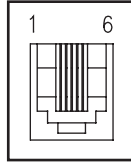

| PIN | SIGNAL | DESCRIPTION |
|-----|--------------------------------|-------------|
| 1 | Signal GND | - |
| 2 | Drawer kick-out drive signal 1 | Output |
| 3 | Drawer open/close signal | Input |
| 4 | +24V | - |
| 5 | Drawer kick-out drive signal 2 | Output |
| 6 | Signal GND | - |

2-3. Loading the Roll Paper

Notes: Be sure to use paper rolls that meet the specifications. Do not use paper rolls that have the paper glued to the core because the printer cannot detect the paper end correctly.

♣ Turn off power switch.

1. Make sure that the printer is not receiving data; Otherwise, data may be lost.
2. Open the paper roll cover by pushing down the cover open push button.

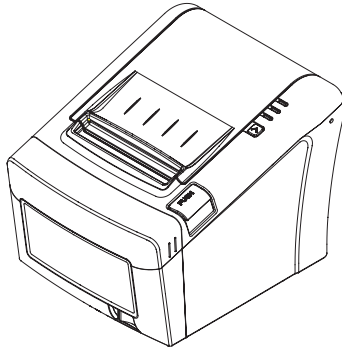

3. Remove the used paper roll core if there is one inside.

4. Insert new paper roll as shown.

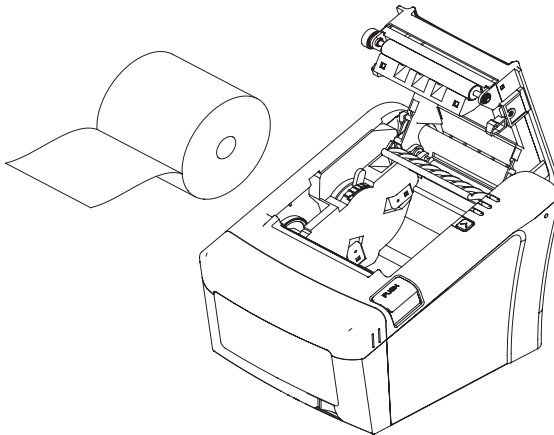

5. Note the correct direction that the paper comes off the roll:

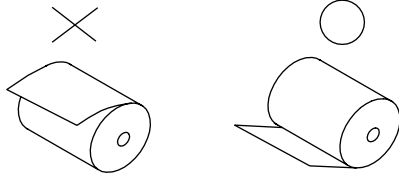

6. Pull out a small amount of paper as shown. Then, close the cover.

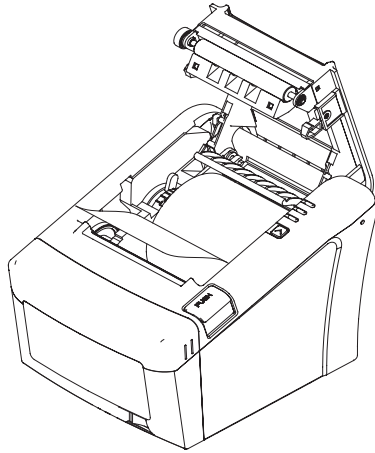

7. Tear off the paper as shown.

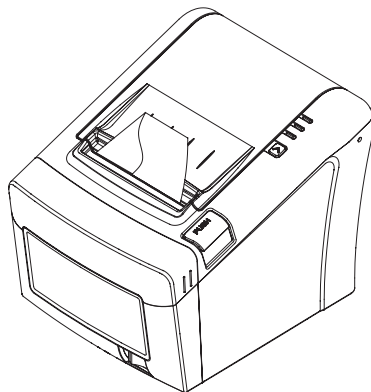

♣ CAUTION:

When the paper cutter is jammed, the top cover might be stuck closed. In this case, repeat power on and off several times.

If the top cover is still stuck, please follow the steps to release the paper jam.

1. Make sure the printer is turned off.
2. Take out cutter cover as shown.

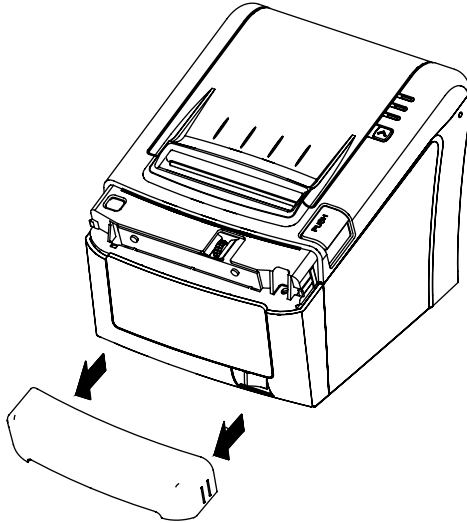

3. Turn the knobble with your finger to clear the paper jam at cutter.

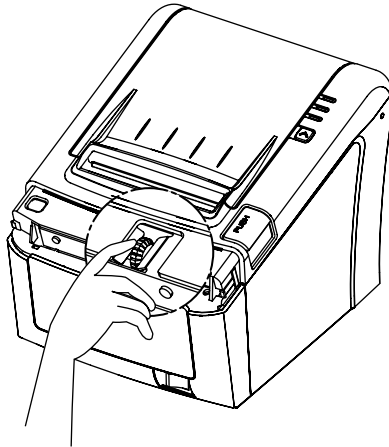

2-4. Adjustment of paper width

1. Please adjust the Paper Guide to fit to the paper width as the direction of arrow.

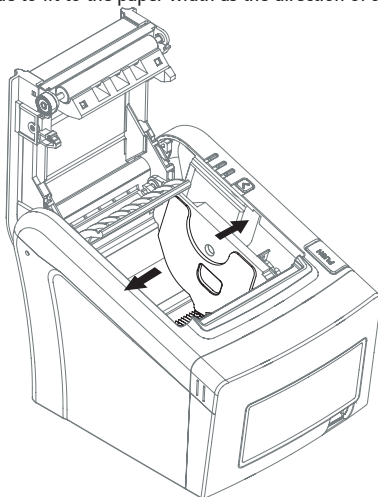

2. Tight the screw after adjusting the Paper Guide.

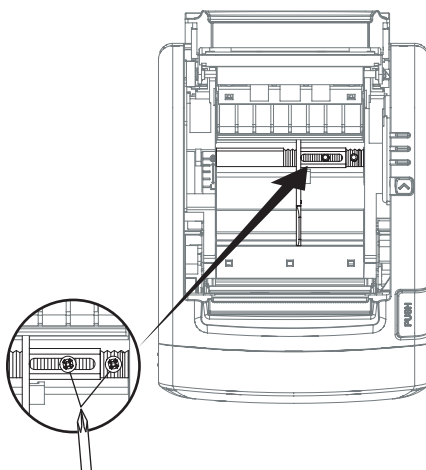

3. Pull the edge of paper once the paper roll is installed correctly and close the Paper Cover.

3. Control panel and other functions

3-1. Control panel

You can control the basic paper feeding operations of the printer with the button on the control panel. The indicator lights let you to monitor the printer's status.

Control Panel

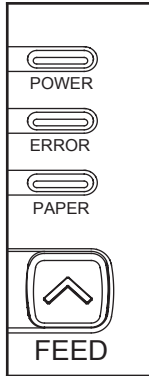

Button

The button can be disabled by the ESC c 5 command.

Press the FEED button once to advance paper one line. You can also hold down the FEED button to feed paper continuously.

3-2. Error indicators

This section explains the different patterns signaled by the two LED indicators located on the top cover of the printer.

| STATUS | PAPER | ERROR | POWER | REMARKS |
|----------------|-------|-------|-------|---|
| | RED | RED | GREEN | |
| Power off | OFF | OFF | OFF | Normal power is not supplied to the printer |
| Power on | OFF | OFF | ON | Normal power is supplied to the printer |
| On line | OFF | OFF | ON | Normal error-free mode |
| Cover open | OFF | ON | ON | Close cover |
| Paper empty | OFF | ON | ON | Insert new paper roll |
| Paper near end | ON | OFF | ON | Paper is low |
| Test mode | OFF | OFF | ON | Ignored error led |

4. Self Test

The self-test lets you know if your printer is operating properly. It checks the control circuits, printer mechanisms, print quality, ROM version and DIP switch settings.

This test is independent of any other equipment or software.

Running the self test

1. Make sure the printer is turned off and the printer cover is closed properly.
2. While holding down the FEED button, turn on the printer using the switch on the front of the printer to begin the self-test. The Self Test prints the printer settings, cuts the paper, then pauses: (Error LED On)

Self-test printing

Please press the PAPER FEED button.

3. Press the FEED button to continue printing.
The printer prints a pattern using the built-in character set.
4. The self test automatically ends and cuts the paper after printing the following.

****** Completed ******

The printer is ready to receive data as soon as it completes the self-test.

5. Hexadecimal Dump

This feature allows experienced users to see exactly what data is coming to the printer. This can be useful in finding software problems.

When you turn on the hex dump function, the printer prints all commands and other data in hexadecimal format along with a guide section to help you find specific commands.

To use the hex dump feature, follow these steps

1. Please turn printer off.
2. Please turn printer on while press down "Feed" button.
3. Please press down "Feed" button more than 3 seconds after print out first page of self test.
4. Now printer had entered into Hexa dump mode.
5. Run any software program that sends data to the printer. The printer prints "Hexadecimal Dump" and then all the codes it receives in a two-column format. The first column contains the hexadecimal codes and the second column gives the ASC II characters that correspond to the codes.

Hexadecimal Dump

1B 21 00 1B 26 02 40 40 !..& . @ @

1B 25 01 1B 63 34 00 1B .%.. c4 ..

41 42 43 44 45 46 47 48 ABCDEFGH

A period (.) is printed for each code that has no ASC II equivalent.

6. Turn off the printer
7. Turn on the printer.

6. Printer cleaning

If the interior of the printer is dusty, printing quality can be lowered. In this case, follow the instructions below to clean the printer.

♣ **Note :**

1. Make sure to turn the printer power off prior to cleaning
2. Regarding print head cleaning, as the print head is very hot during printing, turn off the printer power and wait approximately 10 minute before start.
3. When cleaning the print head, take care not to touch the heated part of the print head. The print head subject to be damaged by static electricity.
4. Take care not to allow the print head to become scratched and /or damaged in any way.

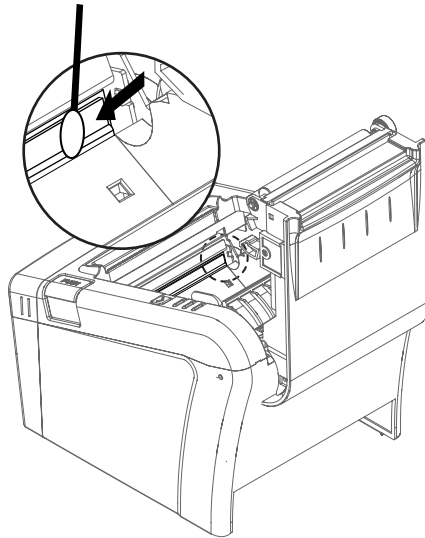

1. Use an applicator swab moistened with an alcohol solution to clean the print head and remove any dusts.
2. Once the cleaning is completed, insert paper roll into the printer few minutes later and close the printer cover.

♣ **Preventing Overheating**

To prevent the motor from overheating, continuous operation of the printer should be 1.5 m or less in print length. Set the pause time for 30 seconds or more than it.

7. Specifications

♣ Important!

When connecting or disconnecting the power supply from the printer, be sure that the following cautions are observed.

Use a power supply (Limited Power Supply) of DC 24V±10% and more than 1.75A.

Be careful about installing the printer in an area where there is electrical noise.

Take the appropriate measure to protect against electrostatic AC line noise, etc.

7-1. General Specifications

(1) Printing Method Direct line thermal printing.

(2) Print speed 160mm/sec

(3) Dot density (Hor / Ver) 180 DPI X 180 DPI

(4) Dot Pitch 0.141mm X 0.141mm

(5) Printing Width Max 72mm (512 dots)

(6) Number of print columns.

| Font "A" | Font "B" |
|------------|------------|
| 42 columns | 56 columns |

(7) Roll paper Refer to chapter 2 for details on the recommended roll Paper.

Paper width : Default 79.5 ±0.5mm

(Min. : 50mm ~ Max. : 82.5mm)

Roll diameter : Max. ø80mm

(8) Weight 1.7 Kg

(8) Overall dimension

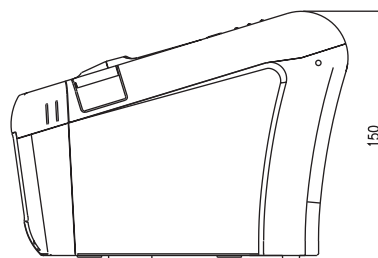
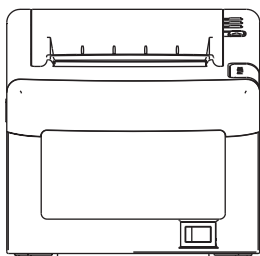
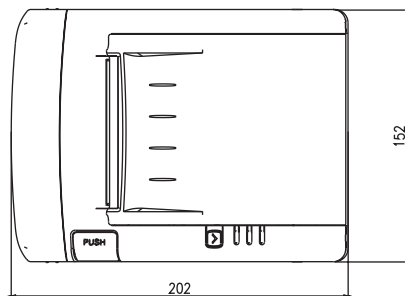

7-2. Auto Cutter Specifications

- | | |
|------------------------|---|
| (1) Cutting Frequency | Max. 30 cuts per minute |
| (2) Thickness of paper | 0.065 ~ 0.09 mm |
| (3) Cutter Life | 1.5 million cuttings (if the paper thickness is between 65 and 80µm) |

7-3. Interface

RS232 Serial Interface, Centronics Parallel Interface(IEEE1284), USB Interface, Ethernet Interface(100Mbps)

7-4. Electrical Characteristics

- | | |
|-------------------------|---|
| (1) Input Voltage | DC 24V ± 10% |
| (2) Current Consumption | Operating: Approx. 1.5 A (at ASC II printing) Peak : Approx. 10 A (at print duty 100%, For 10 seconds or less) Stand-by : Approx. 0.03 A |
| (3) Power Connector | |

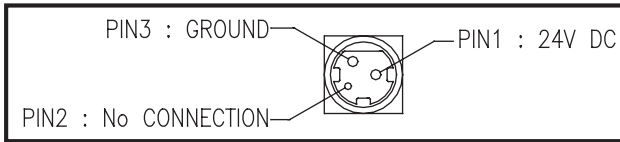

7-5. Environmental Requirements

(1) Operating
Temperature 5°C to 40°C
Humidity 10% to 90% RH (without condensation)

(2) Transport/Storage (except paper)
Temperature -20°C to 60°C
Humidity 10% to 90% RH (without condensation)

7-6. Reliability

(1) MCBF 50 million lines (based on an average printing rate of 12.5% with paper thickness in the range 65µm to 75µm)
 35 million lines (based on an average printing rate of 12.5% with paper thickness in the range 76µm to 150µm)

(2) Head Life 100 million pulses, 150Km

(3) Cutter Life 1.5 million cuttings (if the paper thickness is between 65 and 80mm)

7-7. Certification

- (1) FCC PART15 CLASS A
- (2) UL/cUL (UL 60950-1)
- (3) KC
- (4) CE-EMCD (CE-EMCD Class B should use Parallel shield Cable complied with IEEE-1284 standards)
- (5) ENERGY STAR

8. Command List

| No. | Command | Function | REMARKS |
|-----|---------|--|---------|
| 1 | HT | Horizontal tab | |
| 2 | LF | Print and line feed | |
| 3 | CR | Print and carriage return | |
| 4 | FF | Print and return to standard mode(in page mode) | |
| 5 | CAN | Cancel print data in page mode | |
| 6 | DLE EOT | Real-time status transmission | |
| 7 | DLE ENQ | Real-time request to printer | |
| 8 | DLE DC4 | Generate pulse at real-time | |
| 9 | ESC FF | Print data in page mode | |
| 10 | ESC SP | Set right-side character spacing | |
| 11 | ESC ! | Select print mode(s) | |
| 12 | ESC \$ | Set absolute print position | |
| 13 | ESC % | Select/cancel user-defined character set | |
| 14 | ESC & | Define user-defined characters | |
| 15 | ESC * | Set bit-image mode | |
| 16 | ESC - | Turn underline mode on/off | |
| 17 | ESC 2 | Select default line spacing | |
| 18 | ESC 3 | Set line spacing | |
| 19 | ESC = | Select peripheral device | |
| 20 | ESC ? | Cancel user-defined characters | |
| 21 | ESC @ | Initialize printer | |
| 22 | ESC D | Set horizontal tab positions | |
| 23 | ESC E | Turn emphasized mode on/off | |
| 24 | ESC G | Turn double-strike mode on/off | |
| 25 | ESC J | Print and feed paper using minimum units | |
| 26 | ESC L | Select page mode | |
| 27 | ESC M | Select character font | |
| 28 | ESC R | Select an international character set | |
| 29 | ESC S | Select standard mode | |
| 30 | ESC T | Select print direction in page mode | |
| 31 | ESC V | Turn 90° clockwise rotation mode on/off | |
| 32 | ESC W | Set printing area in page mode | |
| 33 | ESC \ | Set relative print position | |
| 34 | ESC a | Select justification | |
| 35 | ESC c 3 | Select paper sensor(s) to output paper-end signals | |
| 36 | ESC c 4 | Select paper sensor(s) to stop printing | |
| 37 | ESC c 5 | Enable/disable panel buttons | |
| 38 | ESC d | Print and feed paper n lines | |
| 39 | ESC p | General pulse | |

| No. | Command | Function | REMARKS |
|-----|-----------------|---|---------|
| 40 | ESC t | Select character code table | |
| 41 | ESC { | Turn upside-down printing mode on/off | |
| 42 | FS p | Print NV bit image | |
| 43 | FS q | Define NV bit image | |
| 44 | GS ! | Select character size | |
| 45 | GS \$ | Set absolute vertical print position in page mode | |
| 46 | GS * | Define downloaded bit image | |
| 47 | GS / | Print downloaded bit image | |
| 48 | GS B | Turn white/black reverse printing mode on/off | |
| 49 | GS H | Select printing position of HRI characters | |
| 50 | GS I | Transmit printer ID | |
| 51 | GS L | Set left margin | |
| 52 | GS P | Set horizontal and vertical motion units | |
| 53 | GS V | Select cut mode and cut paper | |
| 54 | GS W | Set printing area width | |
| 55 | GS \ | Set relative vertical print position in page mode | |
| 56 | GS a | Enable/disable Automatic Status Back(ASB) | |
| 57 | GS f | Select font for HRI characters | |
| 58 | GS h | Set bar code height | |
| 59 | GS k | Print bar code | |
| 60 | GS r | Transmit status | |
| 61 | GS v 0 | Print raster bit image | |
| 62 | GS w | Set bar code width | |
| | | | |
| | | | |
| | < Add > | | |
| 1 | ESC i | Full cut | |
| 2 | ESC m | Partial cut | |
| 3 | FS ! | Set print mode(s) for Kanji characters | |
| 4 | FS & | Select Kanji character mode | |
| 5 | FS - | Turn underline mode on/off for Kanji character | |
| 6 | FS . | Cancel Kanji character mode | |
| 7 | FS 2 c1 d1...dk | Define user-defined Kanji characters | |
| 8 | FS C | Select Kanji character code system | |
| 9 | FS S 1 2 | Set Kanji character spacing | |
| 10 | FS W | Turn quadruple-size mode on/off for Kanji character | |

